

**Ringschrauben DIN 580  
mit UNC-Gewinde**

Werkstoff: C15E  
Ausführung: roh, galv. verzinkt

**Eye Bolts DIN 580  
with UNC-Thread**

Material: C15E  
Type: self coloured, galvanized

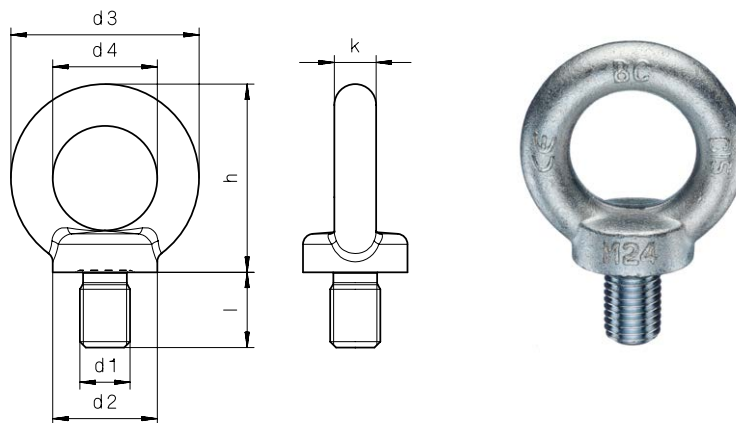

Artikel-Nr. Article-No.	Gewinde ( d1 ) Thread ( d1 )	d2	d3	d4	h	k	l	Tragfähigkeit einsträngig in kg bearing strength upright in kg	Tragfähigkeit zweisträngig in kg 45 ° bearing strength diagonal in kg 45 °	Gewicht kg/ 100 Stck. Weight kg/100 pieces
1030	1/4" Körper 8	20	36	20	36	8	13	70	50	6
1031	5/16" Körper 8	20	36	20	36	8	13	140	95	6
1032	3/8" Körper 10	25	45	25	45	10	17	230	170	11
1033	1/2" Körper 12	30	54	30	53	12	20,5	340	240	18
1035	5/8" Körper 16	35	63	35	62	14	27	700	500	28
1036	3/4" Körper 20	40	72	40	71	16	30	1200	830	45
1037	7/8" Körper 24	50	90	50	90	20	36	1500	1050	74
1038	1" Körper 24	50	90	50	90	20	36	1800	1270	74
1039	1 1/8" Körper 30	65	108	60	109	24	45	2500	1650	166
1040	1 1/4" Körper 36	75	126	70	128	28	54	4300	3200	265
1041	1 1/2" Körper 42	85	144	80	147	32	63	6100	4300	403
1042	1 3/4" Körper 48	100	166	90	168	38	68	8000	5500	638
1043	2" Körper 48	100	166	90	168	38	68	9900	7300	638
1044	2 1/4" Körper 56	110	184	100	187	42	78	11500	8300	880
1045	2 1/2" Körper 64	120	206	110	208	48	90	16000	11000	1240

Maße in mm  
Dimensions in mm

Zwischenabmessungen und Sondergewinde auf Anfrage!  
Intermediate sizes and special thread are available on request!

Maßangaben sind annähernd. Änderungen vorbehalten.  
Dimensions are approximate. Subject to change without notice.