

**Ringmuttern DIN 582
mit UNC-Gewinde**

Werkstoff: C 15E
Ausführung: roh, galv. verzinkt

**Eye Nuts DIN 582
with UNC-Thread**

Material: C 15E
Type: self coloured, galvanized

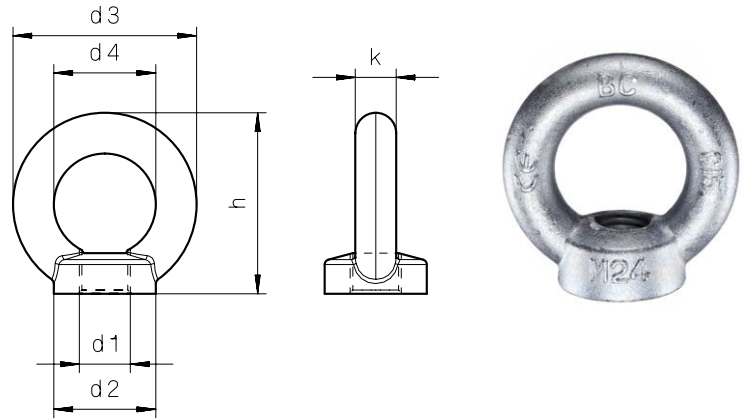

Artikel-Nr. Article-No.	Gewinde (d1) Thread (d1)	d2	d3	d4	h	k	Tragfähigkeit einsträngig in kg bearing strength upright in kg	Tragfähigkeit zweisträngig in kg 45° bearing strength diagonal in kg 45°	Gewicht kg/ 100 Stck. Weight kg/100 pieces
1050	1/4" Körper 8	20	36	20	36	8	70	50	5
1051	5/16" Körper 8	20	36	20	36	8	140	95	5
1052	3/8" Körper 10	25	45	25	45	10	230	170	9
1053	1/2" Körper 12	30	54	30	53	12	340	240	16
1054	9/16" Körper 16	35	63	35	62	14	340	240	24
1055	5/8" Körper 16	35	63	35	62	14	700	500	24
1056	3/4" Körper 20	40	72	40	71	16	1200	830	36
1057	7/8" Körper 24	50	90	50	90	20	1500	1050	72
1058	1" Körper 24	50	90	50	90	20	1800	1270	72
1059	1 1/8" Körper 30	65	108	60	109	24	2500	1650	132
1060	1 1/4" Körper 36	75	126	70	128	28	4300	3200	208
1061	1 1/2" Körper 42	85	144	80	147	32	6100	4300	311
1062	1 3/4" Körper 48	100	166	90	168	38	8000	5500	502
1063	2" Körper 48	100	166	90	168	38	9900	7300	502
1064	2 1/4" Körper 56	110	184	100	187	42	11500	8300	669
1065	2 1/2" Körper 64	120	206	110	208	48	16000	11000	930

Maße in mm
Dimensions in mm

Zwischenabmessungen und Sondergewinde auf Anfrage!
Intermediate sizes and special thread are available on request!

Maßangaben sind annähernd. Änderungen vorbehalten.
Dimensions are approximate. Subject to change without notice